

MIXER PROCESSOR

BLACET RESEARCH MODEL 2040 Mixer/Processor

Users Manual

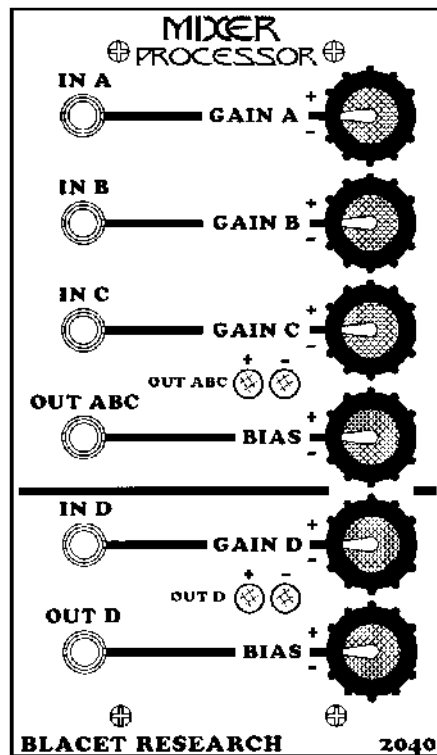

Blacet Research 15210 Orchard Rd Guerneville CA 95446
blacet@metro.net <http://www.blacet.com> 707-869-9164

Contents Copyright.

Reproduction by any means including the Internet prohibited without permission.

Introduction

The Blacet Mixer/Processor is a DC-coupled mixer suitable for both audio and CV mixing. Each input is center-off with plus and minus phase control. The outputs may be level shifted with a variable +5V to -5V bias control. Two separate sections are included: a three input section and a one input section. LEDs on the output indicate plus and minus voltages or are both lit in the presence of AC.

The Mixer/Processor is carefully designed for optimum, stable CV mixing as well as low distortion, low noise audio mixing. CV mixing with the unit allows modulating any voltage controlled module with a highly flexible mix of CV sources such as LFO's, ADSRs, envelope followers, MIDI to CV convertors, CV pedals, etc. Audio mixing with the 2040 allows precise phase control of the input signals resulting in strikingly different sounds unavailable with common uni-phase mixers. The bias control allows easy "overdriving" to down line processors.

Front Panel Controls

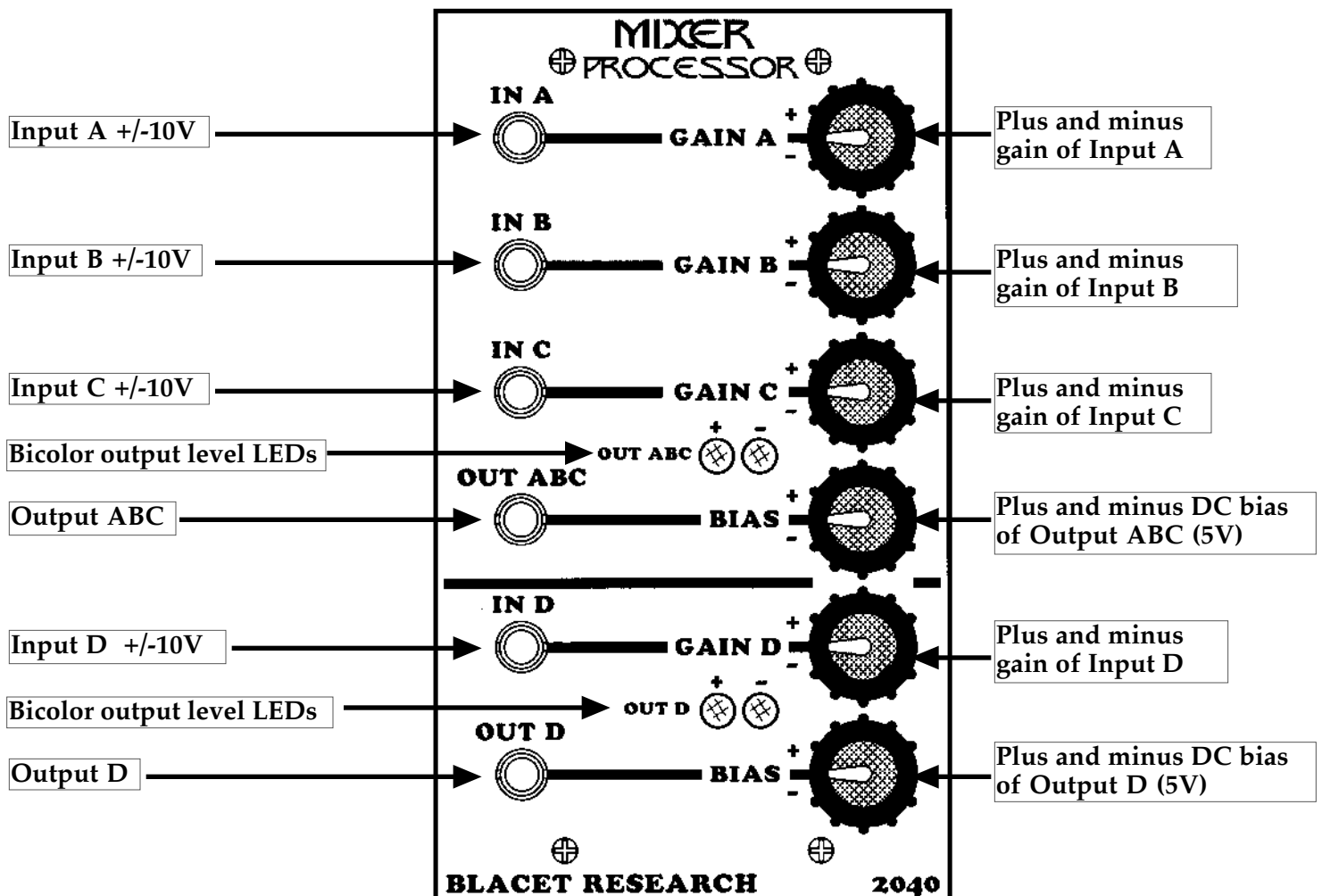

Controls and Operation

Operation of the Mixer/Processor is fairly obvious. You can mix audio signals or DC voltages or a mix of the two. You can bias the outputs with a variable +5V to -5V. The maximum output level of the device is subject to the power supply used; with +/-15V, the output can swing approximately +13 to -13V, so the sum of inputs A, B and C, plus the Bias level will be limited to these voltages. Note that Input D is a separate section with a +/- level and bias control.

Mixing an audio signal with the bias voltages can result in some pot noise, so avoid doing this in critical situations. Use of the bias voltages will typically be with other control voltages such as ADSR or LFOs.

The center detent position of each control is nominally "Off" or "0", although mechanical hysteresis in the controls may allow a small amount of signal feedthru. To minimize this situation, trimmers on the PCB have been adjusted for best "null". Approaching the center detent from the "+" or "-" direction will result in slightly different null points, so the trimmers have been set for best results coming from the "+" side of the rotation.

The control slope of the pots has been flattened around the center position to about 2/3rds of the way out to FCW and FCCW. At these points, the control response curve speeds up considerably. This allows finer control at lower audio and CV levels.

Although it is unlikely in a modern electronic circuit, some devices you may want to connect to the Mixer/Processor might have high DC levels present in their audio output signals. This may cause unexpected results. This situation would be indicated by either output LED showing a DC voltage when a device is connected, but no audio (or other mixer signals) are present.

Block Diagram

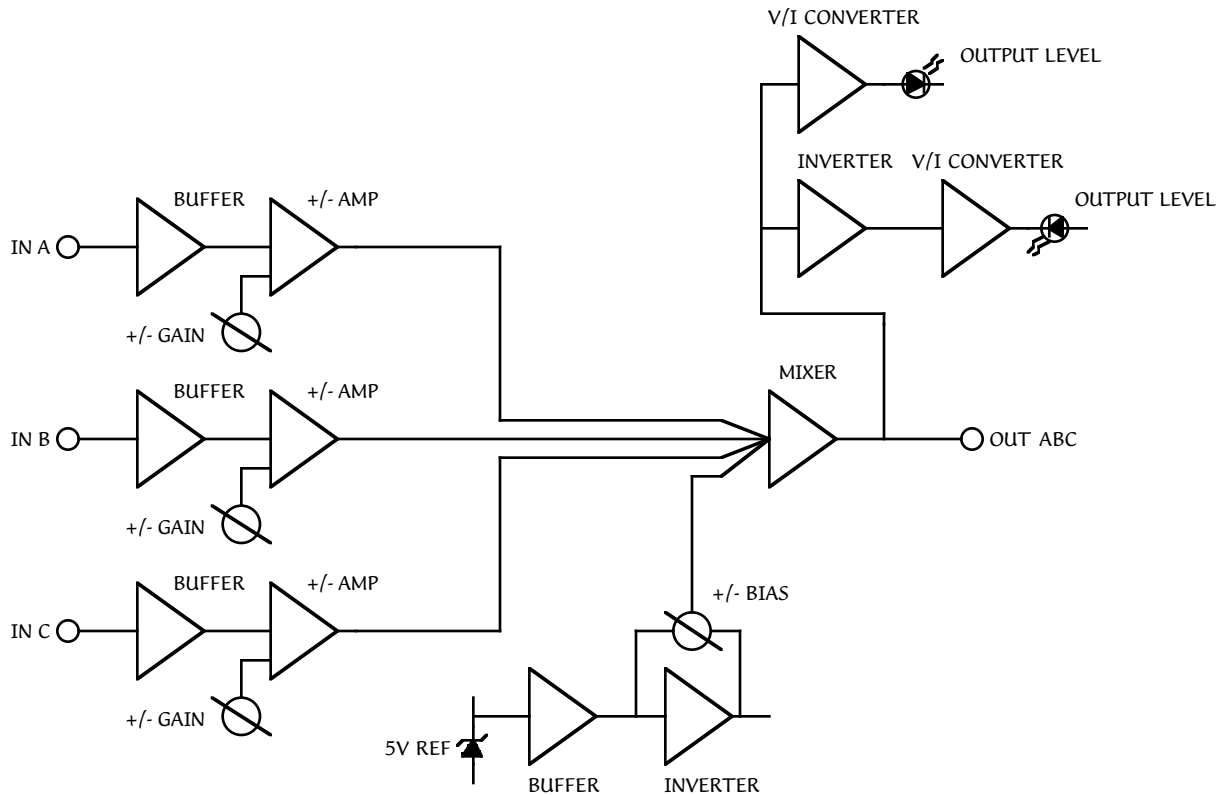

Calibration

There are six "Null" trimmers on the PCB. R9, R15, R21 and R31 are adjusted by applying an audio signal to IN A thru IN D, respectively and monitoring the output of the Mixer/Processor at OUT ABC or Out D. Adjust the trimmers for least signal feedthru when the pot is rotated from the "+" side to the center (OFF) position.

Trimmers R27 and R38 are used to null the Bias voltage at Out ABC and Out D respectively, when the Bias controls are in the center position. With no signals present at the Inputs, measure the voltage at the outputs and adjust for minimum output.

Repair

If you encounter problems that you can't solve, contact us, preferably via e-mail with a description of the problem. We can then help you get your module working.

Warranty

The parts contained in this unit have been carefully selected and tested. They are guaranteed for 90 days from the date of purchase. If you believe that you have a defective part (or if you have a part missing), contact us so we can provide you with a replacement or repair.

Specifications

Front Panel Size: 5.25 x 3" W

Module Depth: 4"

Input/Output Jacks: 3.5 mm (1/8")

Input Level: +/-10V typ.

Output Level: +/-13V (+/-15V supplies)

Bias Level: -5 to +5V

Power: +/-12 to +/-15 Vdc @+35/-35mA (+/-18V regulated or unregulated DC may be used providing U1 and U2 are installed and the bypass traces around them are opened.)

Front Panel Assembly

